



skytec

PRODUCTS & SERVICES PORTFOLIO

DESIGNED. CERTIFIED. DELIVERED.

[SKYTEC-AERO.COM](https://skytec-aero.com)

+43 2638 20305

OFFICE@SKYTEC-AERO.COM



skytec

ONE INTEGRATED PARTNER FOR AIRCRAFT CABIN PROJECTS

Aircraft cabin modifications involve multiple disciplines, interfaces, and strict regulatory requirements.

When design, certification, production, and installation support are managed by separate parties, projects often face challenges such as:

- Interface gaps and unclear responsibilities
- Late design changes affecting certification and production
- Extended lead times and unexpected aircraft downtime

For operators and aviation partners, this translates into increased risk, higher costs, and reduced fleet availability.

At Skytec, we address this complexity with a fully integrated, end-to-end approach, ensuring clarity, efficiency, and reliable project execution from start to finish.

→ **+200**

Customers
worldwide

→ **+500**

Successful Projects

→ **0 to 100%**

From design and
certification, to
production and
consultancy





WELCOME TO SKYTEC

Skytec is a certified EASA Design and Production Organisation, specializing in aircraft cabin interior modifications. Founded by industry veterans with over 40 years of combined experience, we bring deep expertise and proven reliability to every project.

We deliver tailored, high-quality solutions that transform cabin environments to meet the exact needs of our clients. From initial concept and design evaluation through engineering, production, certification, and final aircraft modification, we provide a seamless, end-to-end service.

Our team of highly skilled professionals is committed to precision, innovation, and excellence at every stage. By combining technical expertise with a client-focused approach, we ensure each project is executed efficiently, compliantly, and to the highest standards.

FROM IDEA TO COMPLETION, SKYTEC IS YOUR TRUSTED PARTNER IN AIRCRAFT CABIN SOLUTIONS.

ROADMAP

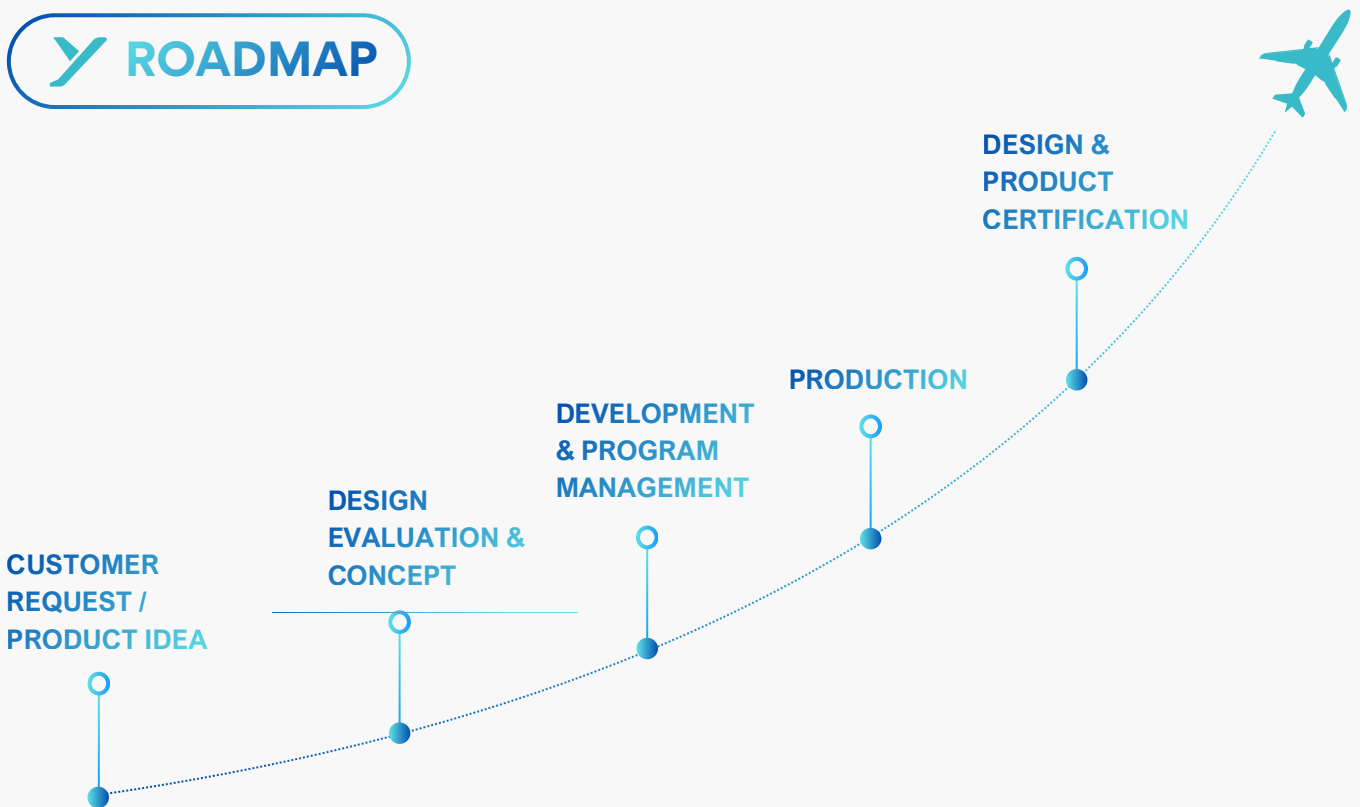



DESIGN & CERTIFICATION



QUALITY IS OUR CORE COMPETENCE

Skytec is your trusted partner for exceptional engineering & certification services. Our team has extensive experience and expertise in a broad range of disciplines, including Avionics, Cabin Interiors, Electrical Systems, Environmental Control Systems, and Structures for CS-25, CS-23 aircraft, and CS-27, and CS-29 rotorcraft.

With our large scope, we cover everything from extensive cabin reconfigurations, cargo compartment modifications, interior refurbishment through cabin electronics such as IFE, ISPSS, or WiFi installations, down to livery changes, decorative adaptations, or registration changes.

CORE COMPETENCIES

- EASA MINOR CHANGES / REPAIRS
 - CABIN INTERIORS
 - PLACARDS
 - TRIM & FINISH
- EASA STC
 - LOPA CHANGES
 - CABIN REFURBISHMENT
 - IFE / ISPSS
- AOG SUPPORT
- THIRD COUNTRY VALIDATIONS
- INVESTIGATION AND DESIGN CONCEPTION
- INSTALLATION DESIGN
- INSTALLATION INSTRUCTIONS
- HARDWARE DESIGN

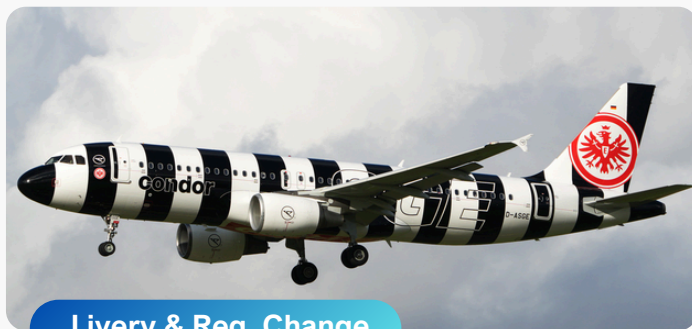

Livery & Reg. Change

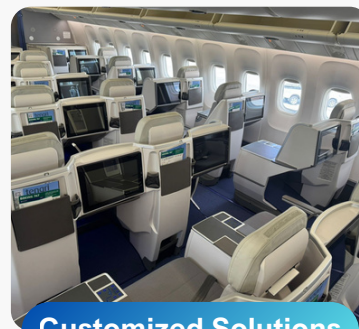

Customized Solutions

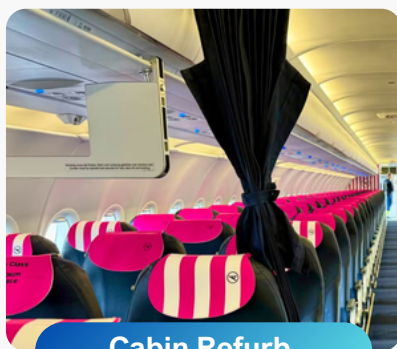

Cabin Refurb.



Electrical Modifications



Cargo Mods.

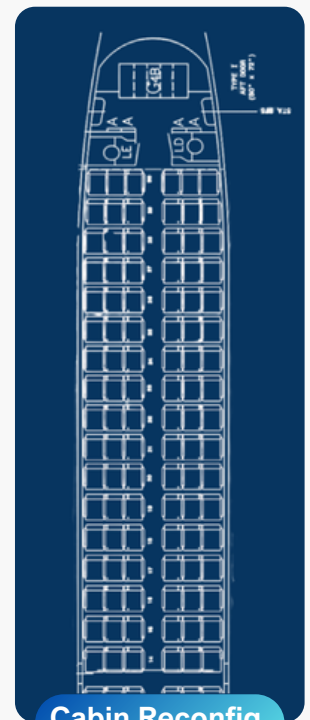

Cabin Reconfig.

WE TAILOR EVERY PROJECT TO YOUR NEEDS, DELIVERING HIGH-QUALITY SOLUTIONS THROUGH CLOSE COLLABORATION. ON TIME, ON BUDGET, AND FULLY COMPLIANT WITH SAFETY STANDARDS.



PRODUCTION

CRAFTING YOUR DREAMS

We specialize in delivering custom interior parts and products that are designed to seamlessly integrate into your aircraft cabin while maintaining the highest quality standards. Our team of experts is dedicated to creating modern and clean designs.

Each of our customers deserves the best, and we are committed to delivering exceptional results on time. We work closely with a network of qualified suppliers and distributors worldwide to ensure that we can find the optimal solution for your needs. From raw materials to brackets, installation hardware, and placards up to fully custom and individual interior parts we can provide everything you need to complete your project.

We also offer pre-assembled electrical harnesses, complete installation kits, OEM parts and even secondhand monuments or passenger seats to meet your specific needs.



CORE COMPETENCIES

- CABIN INTERIOR PARTS
 - WINDSCREENS
 - MOVABLE CLASS DIVIDERS
- INTERIOR / EXTERIOR PLACARDS
- TEMP. REGISTRATION KITS
- METAL PARTS
 - BRACKETS
 - THRESHOLDS
- SOFT FURNISHINGS
- KITTING SERVICES
- SECOND HAND PARTS
- EASA FORM 1



ALL PRODUCTS INCLUDE EASA FORM 1 CERTIFICATION, WITH OPTIONAL FULL LOGISTICS AND DELIVERY TO THE FINAL DESTINATION.



PARTS SOURCING

MISSING PARTS?

FROM SURPLUS TO NEW: FAST, RELIABLE SOURCING WORLDWIDE

Finding the right parts at the right time can be challenging due to limited availability and long lead times. Skytec quickly secures OEM parts, surplus components, seats, and emergency equipment through its global network.



OEM parts sourcing through trusted suppliers



Surplus components sourced quickly worldwide



Emergency equipment sourcing for immediate needs



One partner coordinating everything: no chasing, no delays

IF A PART SLOWS YOUR PROJECT, WE SOLVE IT, FAST AND WITHOUT HASSLE FOR YOU.





CONSULTANCY, TRAINING & COACHING

EMPOWERING QUALITY. ENSURING COMPLIANCE.

At Skytec, we combine decades of aviation experience with one of the broadest regulatory skill sets in the industry. Our experts master EASA regulations, EU requirements, AS/EN 9100/9110, ISO 9001, and more, allowing us to assess your organization from every quality and compliance angle.

This cross-standard expertise enables us to identify gaps quickly, simplify complex requirements, and develop solutions that are both practical and fully compliant. Through our Consulting, Training & Coaching services, we help you strengthen your systems, build internal competence, and elevate overall performance.



PROFESSIONAL TRAININGS

Our tailored courses (Part 21, Part M, Part 145, DOA/POA, EN/AS 9100/9110, ISO 9001) build real competence and prepare your team for regulatory demands. Trainings are practical, customizable, and suitable for all levels, delivered on-site, online, or in a hybrid format.



COACHING & COMPETENCE DEVELOPMENT

We coach management and technical staff for roles such as Form 4 Holders, CVE, Certifying Staff, and Quality or Safety Managers—building confidence and competence in regulatory responsibilities with practical, experience-driven guidance.



AVIATION & QUALITY MANAGEMENT CONSULTING

We assist with system implementation, process optimization, feasibility studies, and documentation aligned with EASA, EN/AS, and ISO requirements. Our consulting ensures efficient, compliant, and future-ready organizational structures.



AUDITING & PROCESS EVALUATION

We perform internal audits, supplier evaluations, and system assessments based on EASA, EN/AS, and ISO standards. We help you identify gaps, prepare for certification audits, and strengthen your operational reliability.

**THIS MULTI-STANDARD PERSPECTIVE ENABLES US TO BUILD
SOLUTIONS THAT ARE HOLISTIC, COMPLIANT, AND FUTURE-READY.**



OUR PORTFOLIO

YOUR COMPLETE CABIN INTERIOR SOLUTION





ALL-IN-ONE IN-FLIGHT ENTERTAINMENT HUB

skybox

The skybox WiFi Server is an all-in-one service hub for in-flight entertainment and comfort, powered by USB-C or a power bank. Its compact ARINC 836A-based design allows easy storage, while built-in firmware enables automatic gate-to-gate operation via flight phase detection.

It integrates seamlessly with IFE and In-Flight Connectivity (IFC) systems through Ethernet, keeping passengers connected and entertained. A 4G or optional 5G modem supports remote updates for fully automatic operation. It is the first in a new line of ARINC 836A and USB-C based products.



Hardware Specifications

- Ultra-portable Lightweight Server (ARINC 836A)
- Intel Alder Lake N Processor
- Up to 16 GB RAM
- Up to 8 TB System Drive
- Up to 16 TB removable Hard Drive
- Bluetooth Client Interface
- Wi-Fi 6 Dual Band Access Point
- Sensor Controller Unit (Motion Sensor, ADS-B,...)
- USB-C Power and Data Interface
- Operating System, including Portal and Routing
- 4G or optional 5G Modem
- Dual Ethernet Interface

A FLEXIBLE IFE AND CONNECTIVITY PLATFORM THAT INSTALLS FAST, OPERATES AUTOMATICALLY, AND SCALES WITH YOUR NEEDS.



ULTRA-PORTABLE LIGHTWEIGHT SERVER	UP TO 8 TB SYSTEM DRIVE	UP TO 16 GB RAM	USB-C POWER AND DATA INTERFACE	BLUETOOTH CLIENT INTERFACE
INTEL ALDER LAKE N PROCESSOR	UP TO 16 TB REMOVABLE HDD	COMPACT DESIGN	INTUITIVE AND SEAMLESS INTERFACE	CENTRALIZED ADMIN MANAGEMENT SUITE



LOPA CHANGES & CABIN RECONFIG.

FEATURES

- Competitive Lead Times
- Experience on Various Aircraft Models
- Comprehensive Solutions
- Use of Surplus Parts
- Including IFE / ISPSS Options

EASA Privilege

Experience swift turnaround times with our streamlined process for Passenger Layout Changes on CS-23 and CS-25 aircraft models. Through our extensive experience and close coordination with our NAA and EASA, we ensure competitive lead times, minimizing downtime and maximizing efficiency for your operations. Our comprehensive solutions encompass every aspect of cabin layout changes, including LOPA drawings, PSU layout optimization, carpet and EEPMS integration as well as IFE and ISPSS adaptation or installation.



Leave the details to us. We handle every aspect of your program, from project management to supplier coordination and hardware sourcing. Plus, with our on-site installation support, you can trust that your project is in capable hands every step of the way.



WE DRASTICALLY SHORTEN CERTIFICATION TIMELINES AND TAKE FULL OWNERSHIP, SO YOUR AIRCRAFT RETURNS TO OPERATION MUCH SOONER.

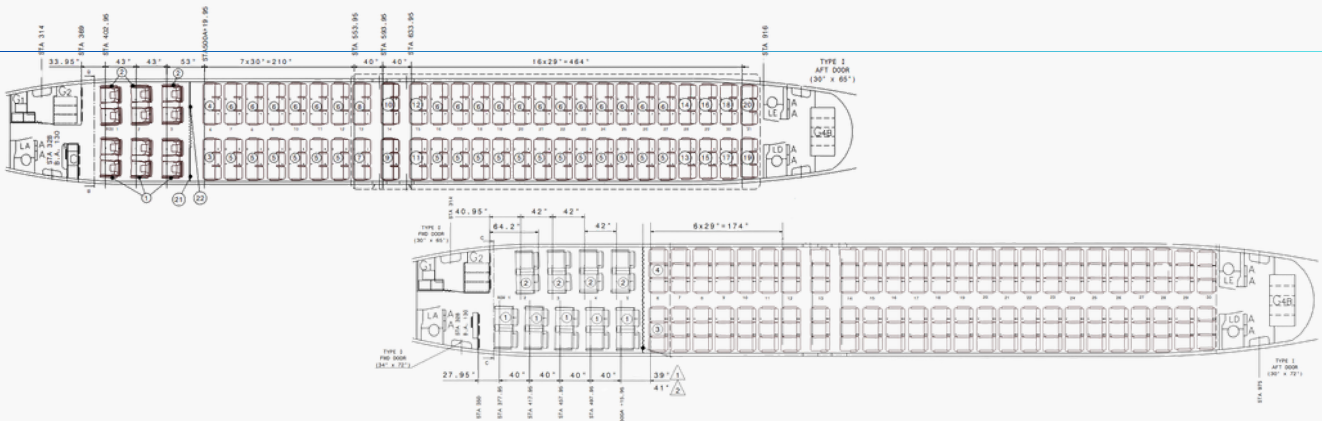

LOPA development & cabin reconfiguration under our DOA

Certain Major Changes & STCs approved in-house via our EASA privilege

Certification lead time cut from ~6 months to ~2 months

Up to 4 months saved, major cost savings for operators & lessors



MOVEABLE CLASS DIVIDER

skyscreen

FEATURES

- Customizable & Compatible
- Easy & Secure Installation
- Comprehensive Cert. & Support



Ultra-Slim Lightweight

As airlines prioritize cabin flexibility, operational efficiency, and improved passenger experience, Skytec introduces skyscreen, a certified retrofit solution for A319, A320, and A321 aircraft. It enables quick, seamless cabin reconfiguration without affecting safety, comfort, or turnaround times.

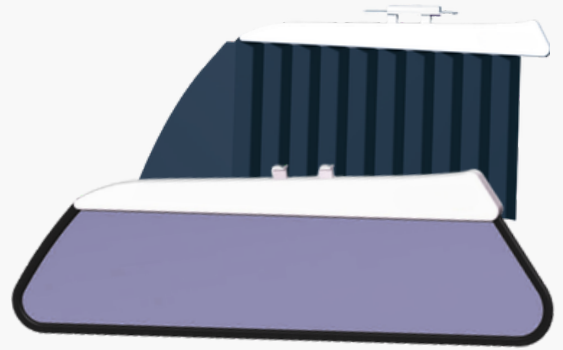

This ultra-slim movable class divider enhances operational agility, allowing crews to easily adapt cabin layouts. It comes in two lateral styles, curtain and mesh, offering flexibility to match branding and service models.

Engineered for durability and simplicity, skyscreen features lightweight components: lateral units under 1.2 kg and a center divider under 2 kg. Its aluminum structure, reinforced with vulcanized white rubber, ensures long-lasting performance while protecting cabin interiors.

Less than
1.2 KG
Per Lateral Part

Less than
2 KG
Per Central Part

Less than
30 S
Reconfig. Time



**A RETROFIT SOLUTION THAT BALANCES
INNOVATION, SAFETY, AND SIMPLICITY**



MOVEABLE CLASS DIVIDER

FEATURES

- Certified with EASA STC
- Easy to Relocate
- Innovative Attaching Mechanism
- Various Customization Options
- No PSU Adjustment Required



High Density Cabins

FLEXIBLE SOLUTION, TAILORED FOR YOU

Our legacy Moveable Class Divider (MCD), specifically designed for the Airbus A320 Family, provides the perfect complement to quickly and effectively divide the cabin classes while offering optimal privacy. Thanks to its unique and innovative attachment mechanism, costly and time-consuming PSU adjustments become unnecessary.

The side panels easily detach and reattach at various locations, while the center curtain header glides effortlessly along the rails, allowing for swift reconfiguration easily managed by the cabin crew.

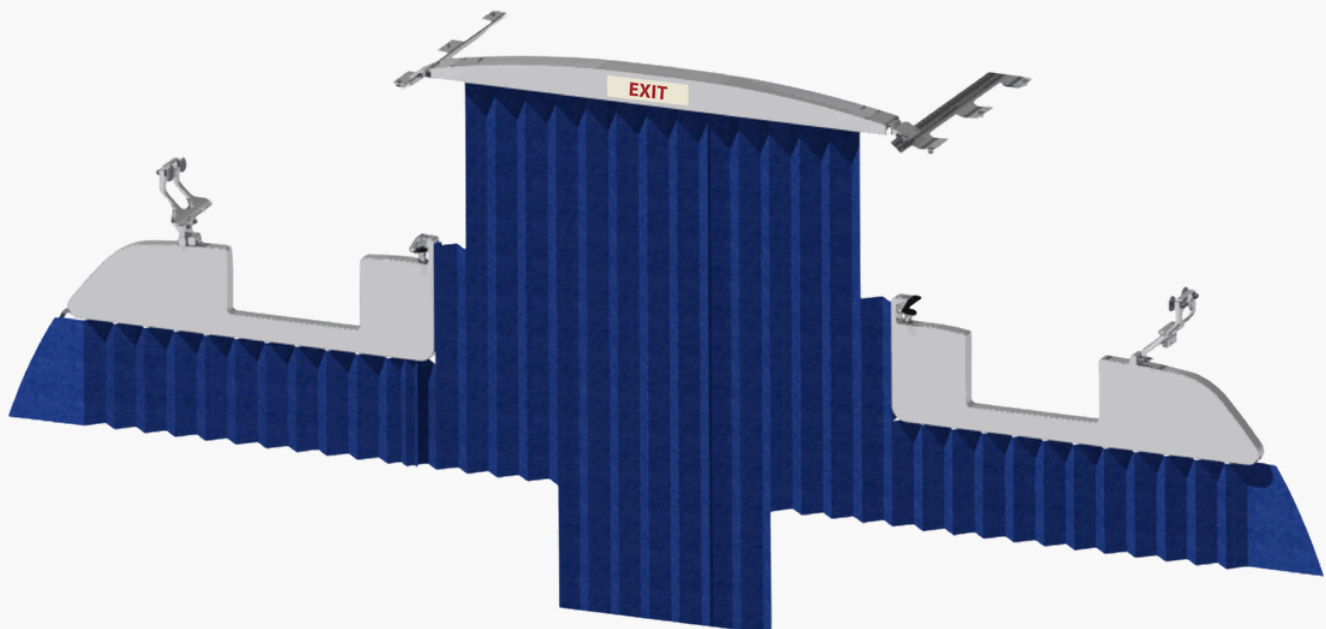

**DESIGNED FOR HIGH-DENSITY CABINS,
AVOIDING PSU RE-ARRANGEMENT**



A32F WINDSCREEN

FEATURES

- Unique and Modern Design
- Frameless Window
- Durable Lightweight Materials
- Adjustable Attachment
- Various Customization Options

FOCUS ON DESIGN AND QUALITY

Introducing our windscreen tailored for Airbus A320-family aircraft (including A318, A319, A320, and A321 models), compatible with both classic and enhanced cabin interiors. Its innovative attachment mechanism enables a 5-inch movement without necessitating any shipside alterations. The unique modern design features a special frameless viewing window meeting the direct view requirements while still providing sufficient privacy for the cabin crew.

Personalize your experience by selecting from a range of customization options. Choose from various optional attaching parts like coat hooks, baby bassinet inserts, bumpers, and literature pockets, available in a spectrum of colors and designs to suit your preferences.

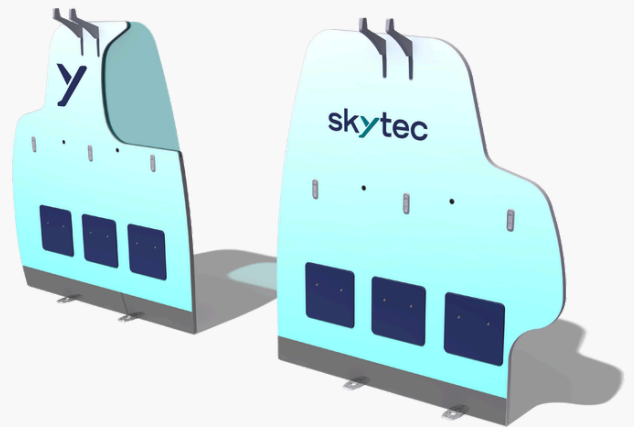

SMART UPGRADE FOR EFFICIENT CABIN INTEGRATION

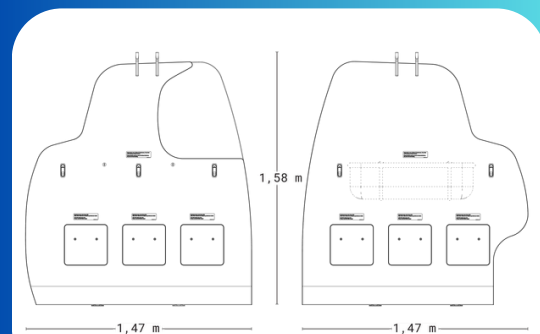



B737 CLASS DIVIDER

FEATURES

- For Boeing Sky Interior
- Lightweight Materials
- Customizable: Placards, literature pockets, baby bassinet, etc.
- Durable Design, Easy Repair/Maintenance

A VERSATILE CABIN ENHANCEMENT

This innovative class divider, designed exclusively for the Boeing 737, can be effortlessly installed at any location within the cabin, offering the utmost flexibility. Crafted from lightweight materials, it is fully tailored to meet your unique vision, featuring customizable decors, literature pockets, coat hooks, baby bassinet, and placards to align with your specific airline branding. This divider is certified for installation under an EASA STC, ensuring top-notch safety and compliance. Plus, short lead times, make it a convenient choice for your aircraft interior upgrade needs. Elevate your cabin experience with the Skytec Class Divider for the Boeing 737.



REDEFINE SPACE, ELEVATE COMFORT.



CREW REST CURTAIN

FEATURES

- Complement for a Class 3 Rest Facility
- Quick Setup and Effortless Operation
- Versatile Application
- Various Customization Options

PRIVACY AND COMFORT FOR YOUR CREW

Designed for simplicity and functionality, this innovative solution provides essential privacy for crew members to rest during extended operations.

The easy-to-install curtain rail will be customized to integrate seamlessly into your Aircraft. Whether utilizing business class or economy class seats, single or multiple rows - the crew rest curtain is the perfect complement for a Class 3 rest facility.

Say goodbye to distractions and hello to recovery as your crew enjoys uninterrupted rest.

The ultimate solution for in-flight comfort and productivity.



**FULLY CUSTOMIZABLE
TO YOUR CABIN**



**EASY INSTALLATION &
SEAMLESS INTEGRATION**

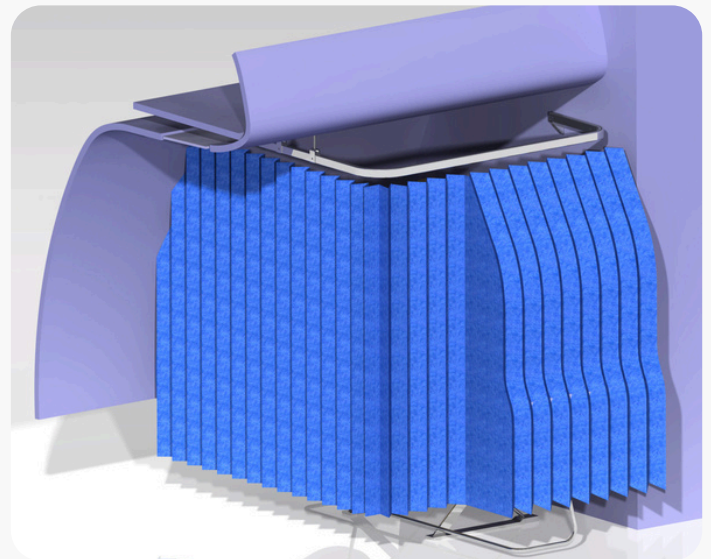
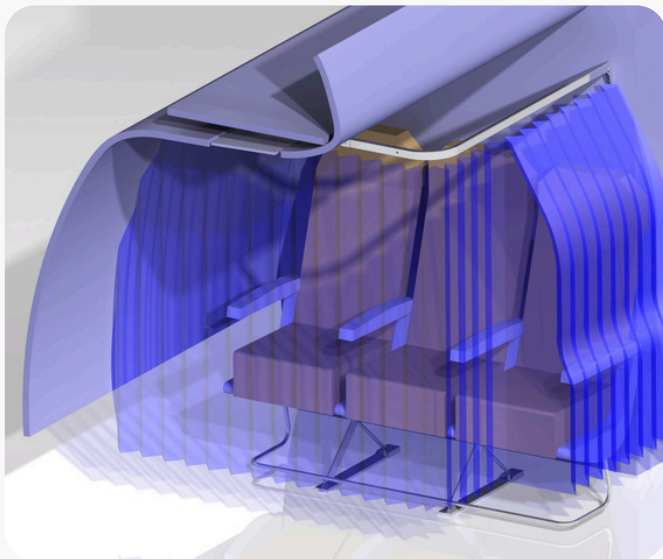

**TURN ANY CABIN SPACE INTO A DEDICATED
CREW REST AREA, QUICKLY AND EFFORTLESSLY.**



CABIN REFURBISHMENTS

FLY IN STYLE, ELEVATING AIRCRAFT INTERIORS

Transform your aircraft's interior with our expansive selection of cabin refurbishment solutions. From sumptuous carpets to refined curtains, from sophisticated seat covers to bespoke logos and branding elements, we provide a wide range of materials, colors, and designs to match your distinct preferences.

With our unwavering dedication to customization, we specialize in crafting items tailored precisely to your aircraft, ensuring a harmonious fusion of style and functionality. Allow us to elevate your cabin's visual allure and take your passengers' experience to unparalleled heights.



Custom components designed and certified under our DOA



Rapid sourcing or in-house production under our POA



Delivered with EASA Form 1 where required



Wide range of in-house designed & produced cabin components

IF THE PART DOESN'T EXIST OR TAKES TOO LONG, WE MAKE IT HAPPEN. YOU DON'T NEED TO WORRY.

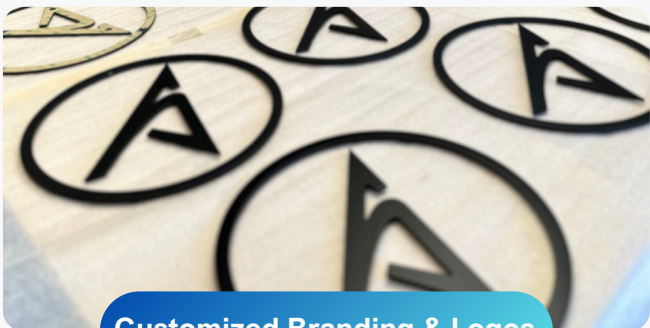

Customized Branding & Logos

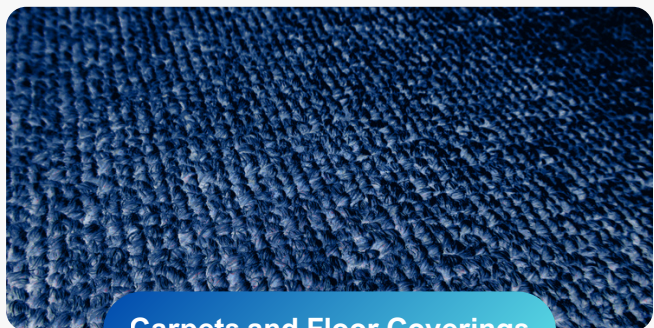

Carpets and Floor Coverings

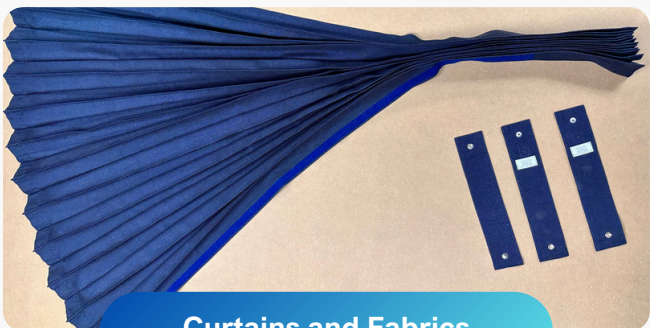

Curtains and Fabrics

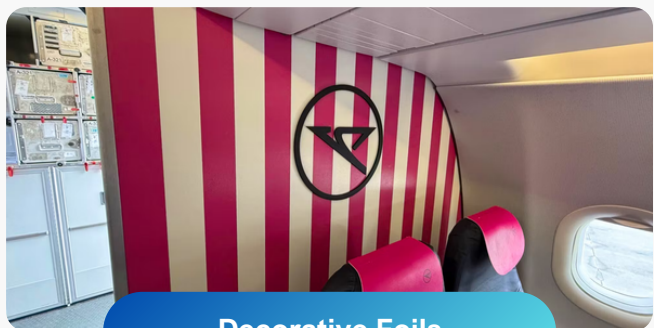

Decorative Foils



CUSHIONS & SEAT COVERS

FEATURES

- End-to-end solution
- BFE & SFE flexibility
- Certified delivery with EASA Form 1
- Wide range of materials & finishes
- Tailored fit for various seat types

SIMPLIFIED. CERTIFIED. DELIVERED.

We deliver complete seat cover and cushion solutions, from design and certification to production and delivery. With proven experience across multiple customers and programs, we support everything from single shipsets to full fleet rollouts.

Our solutions cover all cabin classes, from economy to business, offering a wide range of materials, finishes, and customization options, including both BFE and SFE solutions. Delivered fully compliant with EASA Form 1, we ensure seamless integration, fast turnaround, and reliable execution, tailored to your aircraft, your timeline, and your standards.





LITERATURE POCKET

FEATURES

- Stock Materials (AOG Lead Times)
- Ultra-Lightweight Design
- Standard Installation Interfaces
- +80 Color Options On-Stock

STYLE AND ORDER AT EVERY ALTITUDE

Skytec's Literature Pocket is designed for operators and MROs who need a simple, compliant, and reliable cabin solution without long lead times. Built with an ultra-lightweight honeycomb panel and fireproof synthetic leather, it integrates seamlessly into existing cabin layouts using standard interfaces. With materials available on stock and in-house production, the Literature Pocket supports rapid replacement, fleet standardization, and AOG scenarios while maintaining a clean and consistent cabin appearance.

DESIGNED TO INSTALL FAST, LOOK CONSISTENT, AND KEEP AIRCRAFT IN SERVICE.

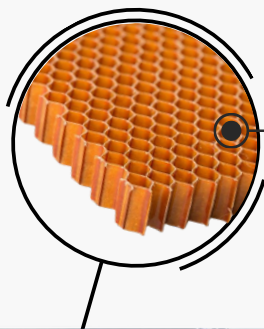

Honeycomb Material

Lightweight Panel



Fireproof Synthetic Leather Cover



+ More than 80 other options



ANTIMACASSAR

WHERE COMFORT MEETS STYLE

CozyMac

Elevate your passengers' in-flight comfort with our premium antimacassar, meticulously designed for compatibility with all aircraft seats. Engineered with an adjustable standard Velcro attachment for effortless installation and featuring soft foam materials, it will enhance relaxation and well-being throughout the journey.

Personalize your CozyMac with your own logo and materials or select a unique design that resonates with your brand identity. Whether you prefer timeless elegance or contemporary flair, CozyMac offers limitless possibilities to elevate your aircraft interiors.

Crafted from flame-retardant materials and subjected to rigorous testing, our antimacassar guarantees unmatched safety and quality standards.

Set new standards with your aircraft interiors and provide passengers with a truly luxurious flying experience courtesy of our esteemed antimacassar.

FEATURES

- Durable and Lightweight
- Fully Customizable Design
- Easy Installation with Velcro Mechanism
- Adjustable Installation Height
- Optional Foldable Ears

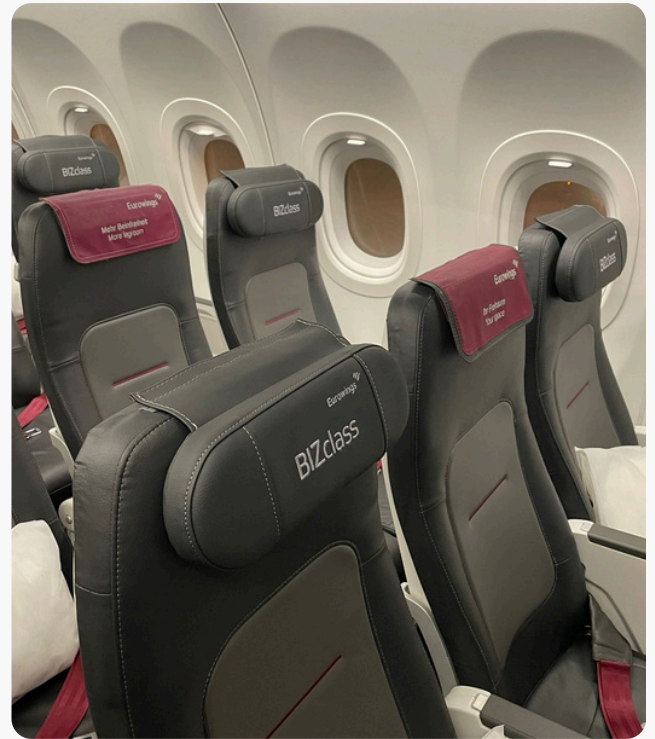



SEAT BLOCKER

FEATURES

- Durable Lightweight Materials
- Adjustable Height
- Fits Most Aircraft Seat Models
- Customization and Branding Options
- Minimum Storage Space
- No Installation Hardware Needed

COMFORT IN THE SKIES

Our innovative Seat Blocker is a functional accessory that easily attaches to an unoccupied aircraft seat, effectively blocking it off for your comfort and privacy. Crafted with convenience in mind, it features two convenient cup holders and acts as a side table, providing a handy surface for passengers seated nearby. With adjustable height, lightweight, and compatible with almost all aircraft seat types, our Seat Blocker is the ultimate travel companion for those seeking comfort and convenience in the sky.

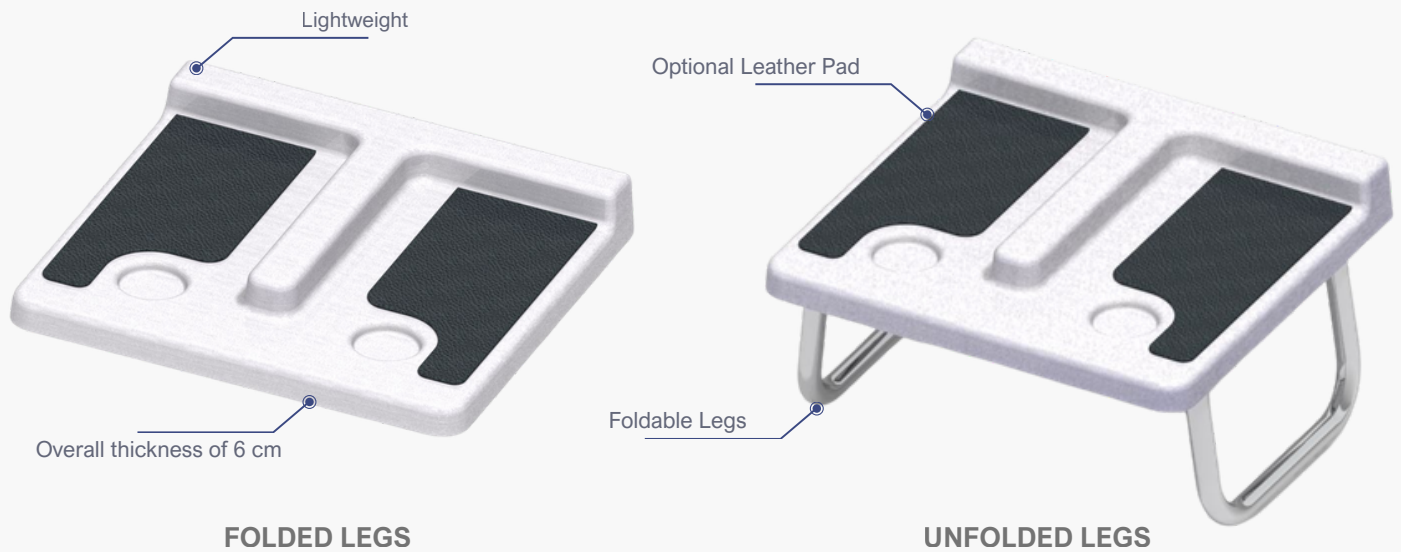



PLACARDS AND MARKINGS

WE PRINT ACCORDING TO YOUR NEEDS

We specialize in manufacturing high-quality interior and exterior placards. From comprehensive interior or exterior kits for aircraft models like the A32F, B737, or E190, to exterior markings, metal plates, and photoluminescent placards, we offer a wide range of solutions to meet your needs. Thanks to our in-house design and production capabilities, we can provide quick turnaround times and support AOG requests. Through our Design Organization Approval (DOA), we have the capability to develop tailor-made placard catalogs. Leveraging our Production Organization Approval (POA), we can also ensure that all placards are accompanied by EASA Form 1 certificates upon delivery.

Just tell us your target, we handle everything else.

 Short lead times

 EASA Form 1 available

 Multilingual, ready-to-install placard kits

 End-to-end: design, cert. & production

FAST DELIVERY, FULL COMPLIANCE, ZERO WORRIES, WE TAKE CARE OF EVERYTHING.

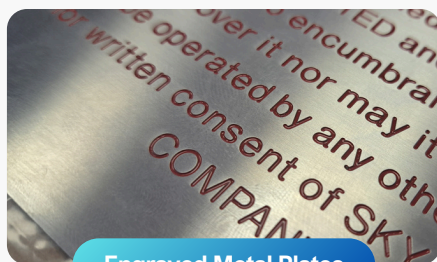

Engraved Metal Plates

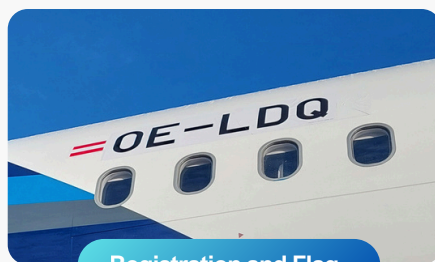

Registration and Flag



Aircraft Interior Placards

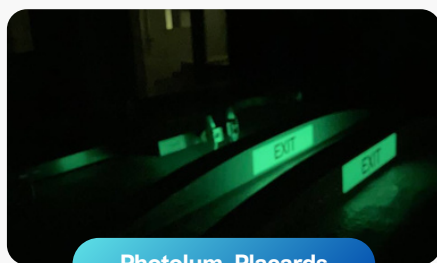

Photolum. Placards

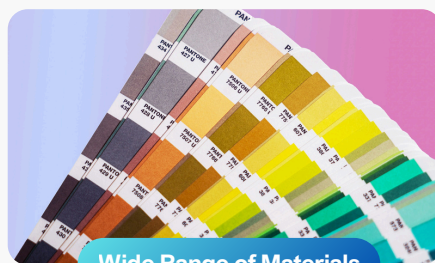

Wide Range of Materials



Specialized Ext. Markings



PLACARD DESIGN AND CERTIFICATION UNDER OUR DOA



READY-TO-INSTALL, CERTIFIED MULTILINGUAL PLACARD KITS



OFF-THE-SHELF KITS FOR A320, A330, B737, E190, AND MORE.



+200

SATISFIED CUSTOMERS





TAKING OFF WITH INNOVATIVE SOLUTIONS



HAVE AN UPCOMING CABIN CHANGE?

Our team is ready to provide fast, clear guidance and customized solutions that keep your aircraft moving on schedule.



Our website ———— www.skytec-aero.com



Our E-mail ———— office@skytec-aero.com



Telephone ———— +43 2638 20305



HQ address ———— Industriestrasse 258,
2722 Weikersdorf, Austria



LinkedIn ———— [skytec-aerospace-gmbh](https://www.linkedin.com/company/skytec-aerospace-gmbh)

